

GRAPE PROCESSING SYSTEMS

MADE BY SCHARFENBERGER

AS

RSS

ES

FB

VM

TS

VS

OS

ACCESSO-
RIES

english



DESTEMMER AS 5-80

QUALITY PREVAILS



EQUIPMENT

- Eccentric destem bar
- Pre-juicing in feed hopper
- Frequency-controlled feeding auger
- Easy cleaning through simple disassembly of the basket and destem bar
- Synchronized movement of basket and destem bar
- Continuous variable speed
- Perforated stainless steel basket 25/22 electropolished
- Stainless steel design

OPTIONS

- Height adjustable stainless steel frame for a ground clearance of 800 – 1300 mm
- Adjustable crushing roller (movable, and easily bypassed)
- Cleaning nozzles
- Additional stainless steel or polyethylene basket with different perforation patterns
- Large feeding hopper

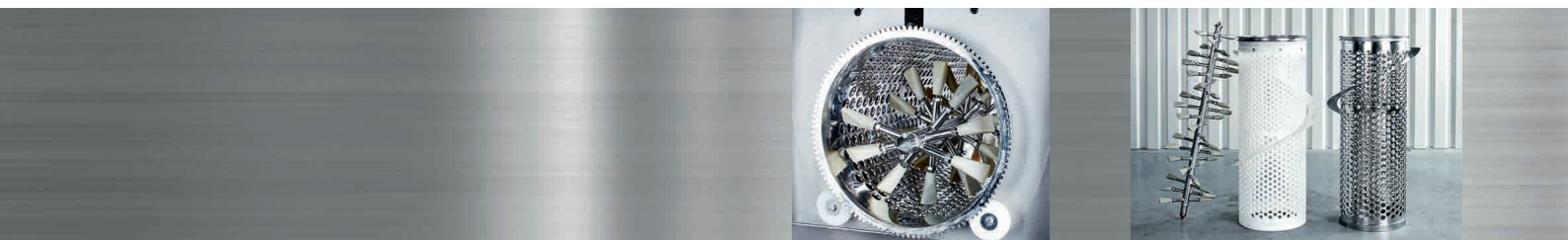



TECHNICAL DATA

Type		AS 5	AS 10	AS 15	AS 25	AS 40	AS 60	AS 80
Capacity t/h*		3-7	6-12	11-18	15-30	25-45	50-60	70-80
Engine power kw	Basket / destem bar	1.1	2.2	2.2	4	5.5	7.5	15
	Feed Auger	0.55	0.55	0.55	1.1	1.5	1.5	1.5
	Crushing roller**	1.1	1.5	1.5	2.2	2.2	3	5.5
Dimensions mm	Length	2,200	2,420	2,730	2,800	3,750	3,880	4,180
	Width	900	900	930	1,150	1,150	1,300	1,340
	Height***	1,900	1,900	1,900	2,050	2,290	2,400	1,860

* depending on the variety and quality of the grapes / ** Option / *** with 800 mm ground clearance



ROLLER SORTER

OPTION FOR THE DESTEMMER AS 5 | AS 10 | AS 15



EQUIPMENT ROLLER SORTER RSS

- Stainless steel version
- Sorting of destemmed berries
- Rollers made out of food grade material
- Roller distance can be adjusted
- Frequency driven motor

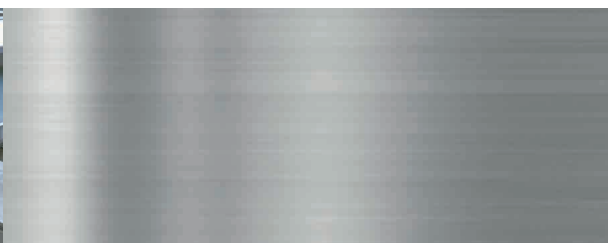
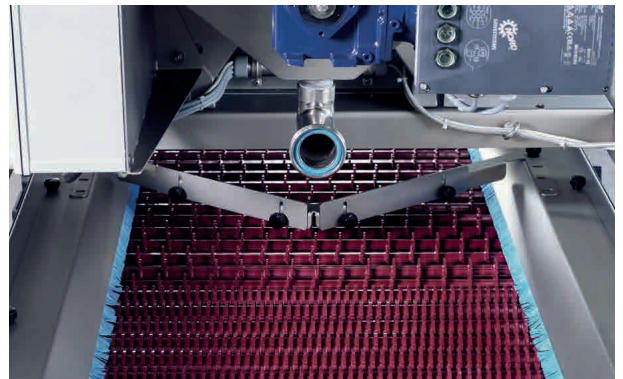

ROLLER SORTER + CRUSHER



OPTION FOR THE DESTEMMER AS 5 | AS 10 | AS 15

EQUIPMENT CRUSHER

- Stainless steel version
- Movable crusher
- Food grade crusher rollers
- Easy to clean
- Frequency driven motor



ROLLER SORTER STAND-ALONE



WITH UNDERFRAME RSS 10 | RSS 15 | RSS 40

EQUIPMENT ROLLER SORTER

- Stainless steel version
- Can be operated as a stand-alone roller sorter
- Rollers made out of food grade material
- Easy to clean
- With rollable leveling feed



EUROSELECT DESTEMMER

INNOVATION FOR THE FUTURE



EQUIPMENT

- Stainless steel design
- Multiple adjusting options to match grape varieties and quality thanks to frequency-controlled drive of the modular conveyor belt and destem finger rollers
- Gentle destemming and sorting during the destemming process
- Easy to clean
- Pre-juicing
- Elastic destemming fingers
- Four casters (two with brakes)
- Low feeding height



Grape chute, mountable on both sides

TECHNICAL DATA

- Capacity up to 5 t/h
- 4 destemming finger rollers can be actuated in pairs due to frequency-controlled drive
- Modular conveyor with frequency-controlled setting
- Reduced circumferential impact on fruit



WHOLE CLUSTER CONVEYOR BELT

FLEXIBLE AND EASY HEIGHT ADJUSTMENT



Optional equipment: Special hopper and grape crusher

EQUIPMENT

- Stainless steel design
- Food-grade conveyor belt
- Hydraulic height adjustment
- Belt tensioning device
- Four casters (two with brakes)
- Sump drain fitting DN 50
- Easy to clean

OPTIONS

- Large feeding hopper with most outlet
- Grape crusher
- Swivel chute
- Cleaning system
- Height adjustable with hydraulic piston

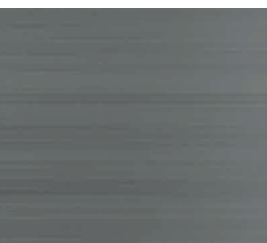

Swivel chute (optional)



Large feeding hopper (optional)

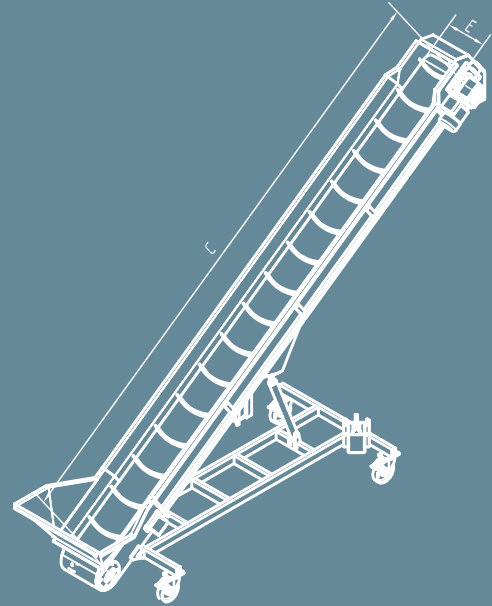
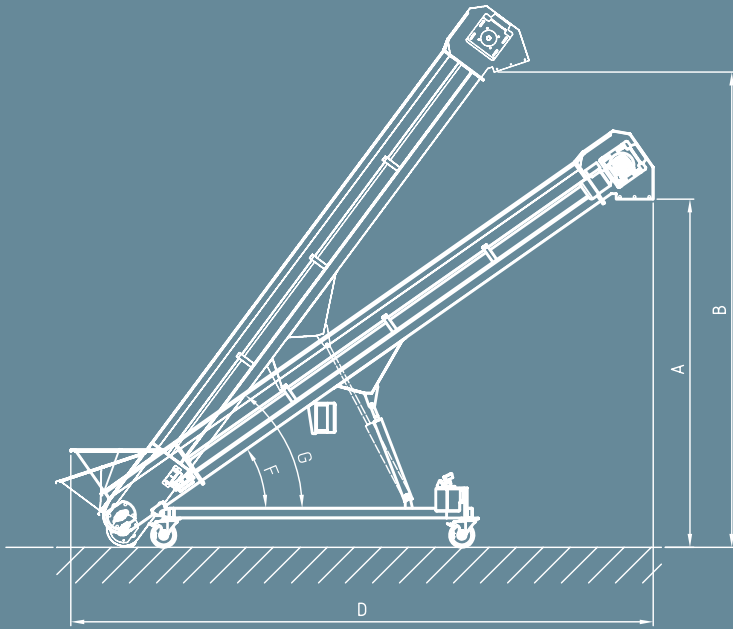

DIMENSIONS

Item	A (mm)	B (mm)	C (mm)	D (mm)	E (mm)	F (°)	G (°)
FB40/17	1,700	2,290	3,000	3,127	400	35	50
FB40/22	2,274	3,105	4,000	3,947	400	35	53
FB40/25	2,297	3,069	4,500	4,579	400	30	43
FB40/28	2,849	3,888	5,000	4,765	400	35	52
FB40/34	3,185	4,374	6,000	5,711	400	32	48
FB40/40	3,604	5,113	7,000	6,634	400	31	47
FB60/17	1,700	2,290	3,000	3,127	600	35	50
FB60/22	2,274	3,105	4,000	3,947	600	35	53
FB60/28	2,795	3,918	5,000	4,928	600	33	52
FB60/34	3,186	4,364	6,000	5,741	600	32	48
FB60/40	3,811	4,849	7,000	6,687	600	32	42

VIBRATION DOSING TABLE



WELL THOUGHT-OUT IN EVERY DETAIL

POSSIBLE APPLICATIONS

- Tipping and adjustable dosing
- Continuous feeding of grapes to a destemmer or grape crusher
- Dosed feeding of an optical sorter with berries
- Using trieur sieves (optional), oxidized juice, insects and grape seeds can be separated



EQUIPMENT

- Stainless steel design
- Vibration discharge
- Easy to clean
- Driven by two frequency-controlled unbalanced motors
- Four casters (two with brakes)

TECHNICAL DATA

- Capacity: 5-10 t/h
- Trough capacity: approx. 1100 l
- Dimensions: (LxWxH)
Model VM 2.0: 2084 x 1590 x 1770 mm
Model VM 2.6: 3020 x 1590 x 1770 mm



SELECTION TABLE

TS

FOR THE HIGHEST DEMANDS

POSSIBLE APPLICATIONS

- Hand-picked selection
- For manual sorting of destemmed grapes after the destemmer with an adjusted belt speed
- Enables the continuous feeding of processing machines such as the optical sorter



EQUIPMENT

- Stainless steel design
- Food-grade conveyor belt
- Frequency-controlled drive motor
- Quick-release mechanism for conveyor belt
- Four casters (two with brakes)
- MOG trays
- Easy to clean

TECHNICAL DATA

- Capacity: 5-10 t/h
- Length: 3000 mm | 4000 mm | 5000 mm
- Conveyor belt width: 600 mm | 800 mm

VIBRATION SORTING TABLE

VS

PERFECTION CAN BE QUITE EASY

POSSIBLE APPLICATIONS

- Tipping and adjustable dosing
- Continuous feeding of grapes to a destemmer or grape crusher
- Dosed feeding of an optical sorter with berries
- Using Trieur sieves (optional), oxidized juice, insects and grape seeds can be separated



EQUIPMENT

- Stainless steel version
- Vibrating discharge
- Driven by two frequency-controlled unbalanced motors
- Pre-juicing pan
- Self cleaning MOG trays
- Large infill hopper
- Four casters, two with brakes
- Easy to clean

TECHNICAL DATA

- Capacity: 5-10 t/h
- Table width: 800 mm
- Dimensions: (LxWxH)
MODEL VS 2.6: 2800 x 1600 x 1710 mm
MODEL VS 3.6: 3760 x 1990 x 1710 mm
MODEL VS 5.0: 5060 x 1990 x 1710 mm



GRAPE CRUSHER



THE PERFECT COMBINATION

EQUIPMENT

- Stainless steel design
- Food-grade rubber crusher rollers
- Easy assembly and disassembly
- Low weight
- Easy to clean
- Can be mounted to the EuroSelect destemmer, whole cluster conveyor or feed hopper on the Europress grape press (optional)

TECHNICAL DATA

- Capacity: up to 20 t/h
- Crusher rollers 300 to 850 mm in length



POMACE TIPPING TRAY



THE ESSENTIAL ASSISTANT

EQUIPMENT

- Stainless steel design

OPTION

- Hydraulic tipping device

TECHNICAL DATA

- Capacity: 800 l 1300 Litres
- Overall height: 440 mm l 640 mm
- Tray dimensions: 1800 x 1600 mm



EUROSELECT OPTICAL SORTER

OPTICAL GRAPE SORTER BY SCHARFENBERGER



EQUIPMENT

- Frame in stainless steel (AISI 304)
- Movable on four wheels (two with brakes)
- Stepless height adjustment and easy levelling
- Belt made out of food-grade material
- Belt with constant speed
- Inspection openings for easy access and fast cleaning
- Removable juice collection tray
- Forklift pockets
- Automatic belt cleaning
- Display on swing out arm
- Waste discharge by auger (left or right side)

TECHNICAL DATA

- Capacity up to 5 t/h (depending on the variety and quality of the grapes)
- Compressed air requirement: approx. 300 l/min at 7 bar
- Electrical connection: 1 x 230 Volt AC
- Length: approx. 2073 mm
- Width: approx. 1655 mm
- Total height: approx. 1996 mm
- Discharge height: approx. 850 mm



GENTLE HANDLING OF THE HEALTHY GRAPES WITH CONSISTENTLY HIGH SELECTION PERFORMANCE



PREMIUM QUALITY WITH SCHARFENBERGER'S OPTICAL GRAPE SORTING



For an optimal presentation of the grapes to the cameras they are spread out on a fast running conveyor belt which is made out of food-grade material. Several inspection openings on the machine ensure good accessibility and guarantee a cleaning quick and easy.



The grapes are rapidly analysed in free fall by HD cameras, and rotten and unripe berries together with any remaining material like stems, leaves, petiols, etc. are reliably removed with compressed air nozzles. Detection is based on the visible colours and infrared.



The touch screen control unit allows an easy and fast detection of desired and undesired colors of the fruit. Based on that information the setting of the color and infrared data can be adjusted.

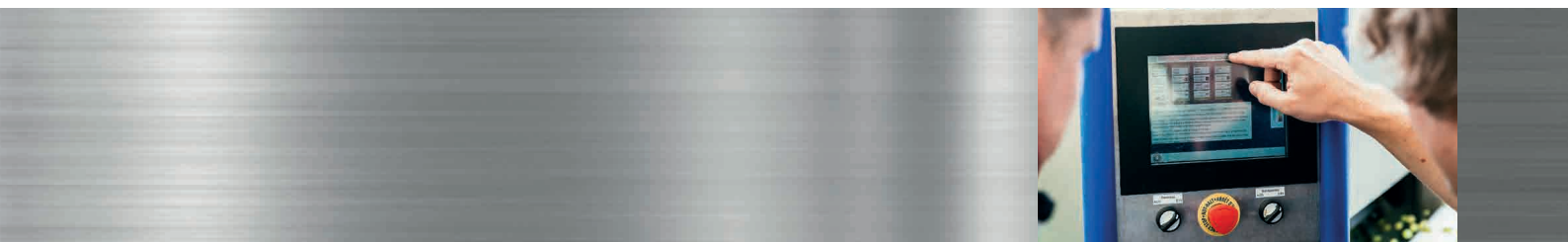

SCHARFENBERGER WORLDWIDE



Canada	Belgium	Austria	Romania	Ukraine	China
USA	Luxembourg	Italy	Serbia	Moldavia	Japan
Mexico	Netherlands	Greece	Croatia	Israel	Australia
Chile	England	Turkey	Slovenia	Georgia	New Zealand
Argentina	Denmark	Albania	Hungary	Russia	
Portugal	Sweden	Uruguay	Slovakia	Kazakhstan	
Spain	Germany	Armenia	Czech Republic	South Africa	
France	Switzerland	Bulgaria	Poland	India	



DIN EN ISO 9001:2015 DGR 2014/68/EU

We reserve the right to make technical changes without prior notice.

Scharfenberger GmbH & Co. KG
Philipp-Krämer-Ring 30 / Gewerbegebiet Bruch / D-67098 Bad Dürkheim
Tel. 0049 - (0) 6322-60 02-0 / Fax 0049 - (0) 6322-60 02-10
info@scharfenberger.de / www.scharfenberger.de

 **Scharfenberger**
Maschinenbau